

23HP Briggs AMT 2.5" Pump Specifications – High Volume Sprinklers

Key Features:

- Briggs & Stratton Vanguard engine
627cc, 2 cylinders, with electric start
with manual recoil backup
 - 15 Foot 2.5" Suction Hose with Cam Lock
connection included
 - Battery and trickle charger installed
 - Pump sprays water 150 feet from 1.5"
nozzle after 100 feet of fire hose
 - Pump produces Max 165 PSI; 155 PSI at
70 GPM, 70 PSI at 240 GPM
 - Pressure Relief Valve protects pump
when nozzles closed and engine running
(20 minutes)
 - Exhaust Primer system driven by
engine
 - Two 1.5" fire hose connection (standard),
or one 2.5" fire hose or piping
connection available
 - Six-gallon gasoline tank for 7 hours of
operation at high speed
 - Portable using 5" Castor Wheels on
Frame (lockable) or can be mounted
stationary
- * Designed for large properties and
systems with High Volume Fire Sprinklers and/or multiple Fire Hose Hydrant systems.**
- ** We can assist with system design.**

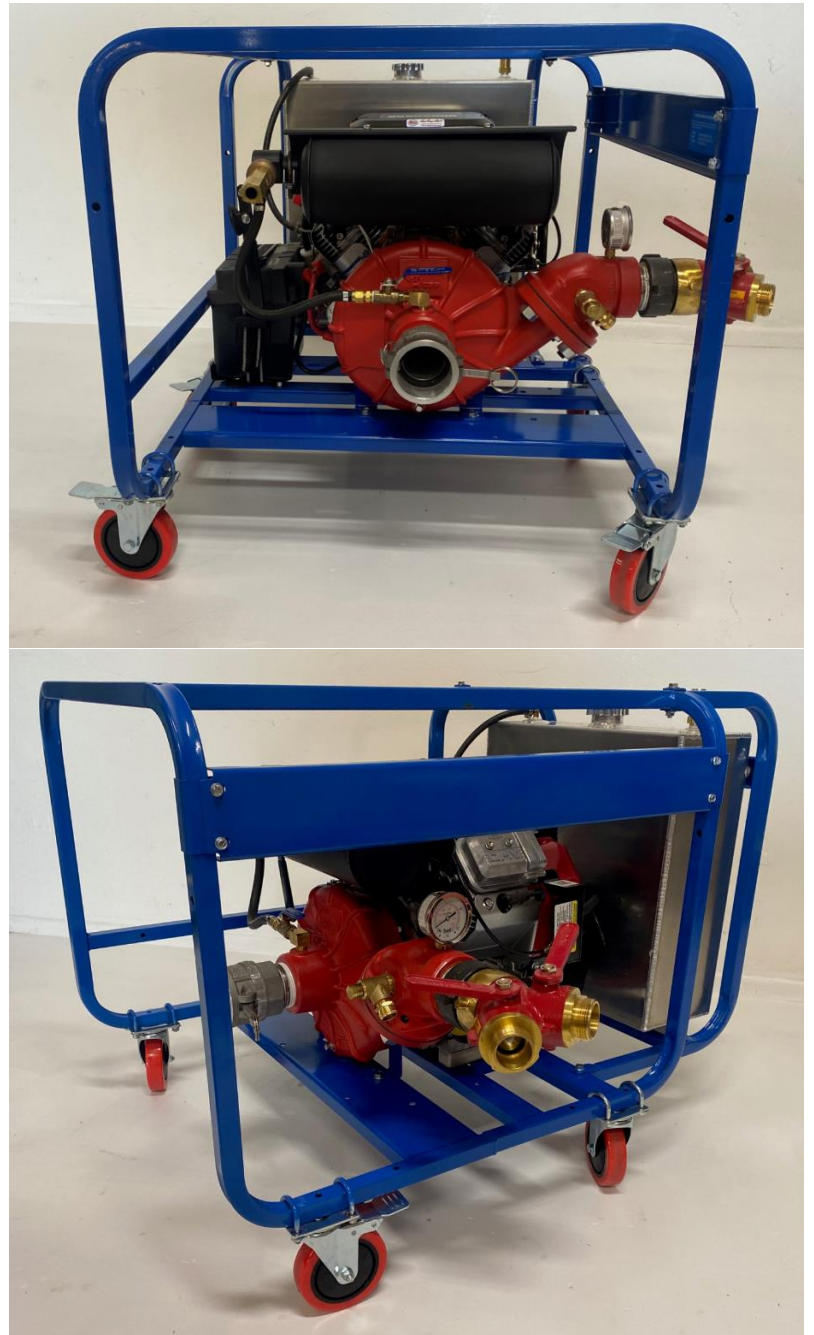

Fire Hoses, Nozzles, and related equipment available at additional cost.



Fire Pump and Hose Packages LLC

1654 West 11th Street Upland, CA 91786

Office (800) 797-1310 Info@FirePumpAndHose.Com

Helping Homeowners protect property from Wildfires with Water Tanks, Fire Retardant Sprayers and Gel, and portable high pressure water pump packages.

23HP Briggs Vanguard AMT 2.5" Intake Fire Pump Package Specifications

Fire Pump Package	23HP Briggs AMT 2.5
Pump Pressure (PSI) at:	
70 GPM	155
100 GPM	145
150 GPM	125
200 GPM	100
250 GPM	60
Water Spray from 1.5" Nozzle after 100 Feet of Fire Hose	150
Factors Affecting Selection:	
Portable	YES, Frame on Casters
Thermo Gel as primary protection	Optional
Water Supply < 3k Gal	NO
Nozzle 20'+ higher than Pump (A)	YES
Nozzle 40'+ higher than Pump (A)	YES
Hose/Pipe Run > 400' level ground	YES
Two 1.5" Fire Hoses Concurrently	YES
Electric Start	YES
Perimeter High Volume Sprinkler System	YES
Exhaust driven Primer	YES
Salt Water	NO
Diesel Fuel	NO
Fire Hose in Standard Package	Optional
Pricing US\$, excluding shipping and CA Sales Tax	
Manual Start	Included
Electric Start (C)	\$ 6,299



Pump Performance Curves 13+ HP Models

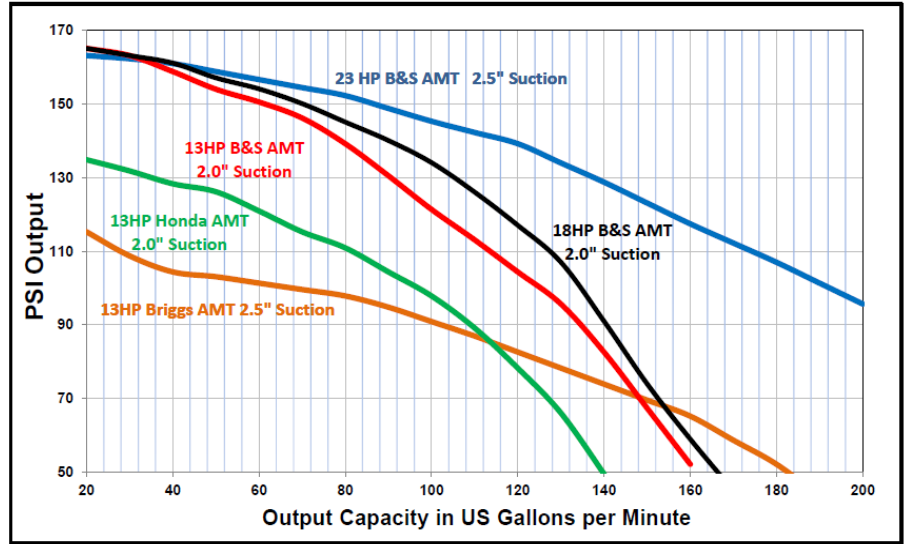

(per manufacturers' specifications at 12/31/2020)

Sold by: Fire Pump and Hose Packages LLC www.FirePumpAndHose.Com
Email: Info@FirePumpAndHose.Com (800) 797-1310

Options Available:

- Electric Vacuum Primer for faster and easier priming with less engine wear.
- Custom Pump Cover for protection of equipment
- Water Tank connection fittings
- Lake/Ocean Float Dock for Suction Hose
- High Volume Filter for Suction Hose

23HP Briggs Vanguard AMT 2.5" Intake Fire Pump Package Specifications



Six-gallon fuel tank supports extended run times for perimeter sprinkler systems.

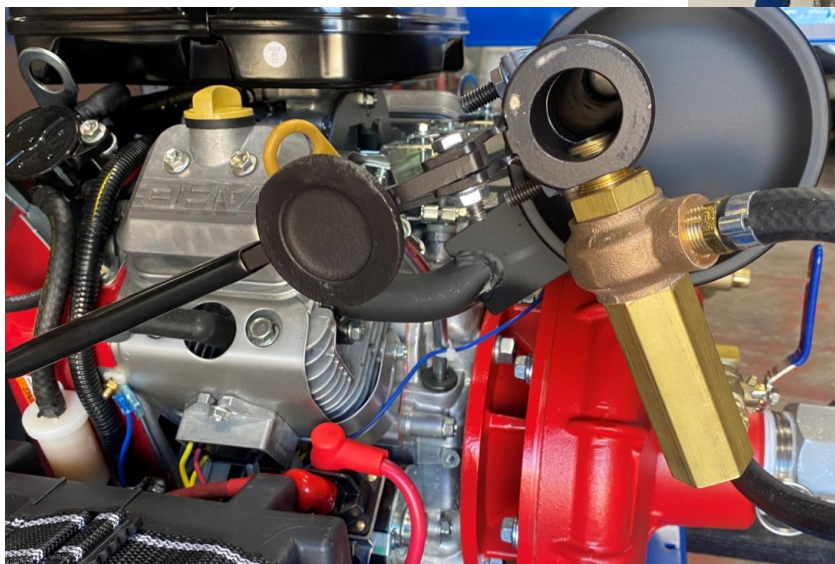

Exhaust Primer detail (left)



2-1/2" Engine Driven High Pressure/Fire Pumps

- Aluminum Construction with Replaceable Hard Coat Anodized Wear Ring
- Viton® Mechanical Seal with Silicon Carbide & Carbon Faces
- 2-1/2" NPT Port Sizes
- Exhaust Prime or Hand Prime Depending on Model
- Prime Assist to 19 Ft.
- Built-in Discharge Check Valve
- Discharge Pressure Gauge Included
- Suction Strainer, Nipples and Heavy Duty Steel Roll Frame with Battery Tray Included
- Maximum Head up to 165 PSI/ 380' TDH
- Delivers to 270 GPM
- Available with B&S Vanguard, Honda Gasoline or Hatz Diesel with 12 Volt DC Electric Start
- Optional NPT to Fire Hose Thread Available – See Accessories Page
- Optional Wheel Kit Available

IPT ENGINE DRIVEN HIGH PRESSURE/FIRE PUMPS

The IPT Engine Driven line of High Pressure/Fire pumps deliver excellent pressure and flow for use in many applications including: fire protection, emergency fire fighting, washdown and AG/Sprinkler. Portable units feature metal fuel tanks installed on engine or frame depending on model. 12 Volt DC electric start engines with recoil starter from Briggs & Stratton Vanguard, Honda Gasoline or Hatz Diesel engines are standard on these pumps. Vanguard models feature built-in exhaust prime. Honda and Yanmar models feature a manual hand prime. These pumps are equipped with Viton® Silicon Carbide/Carbon seal and Viton® O-rings/gaskets.

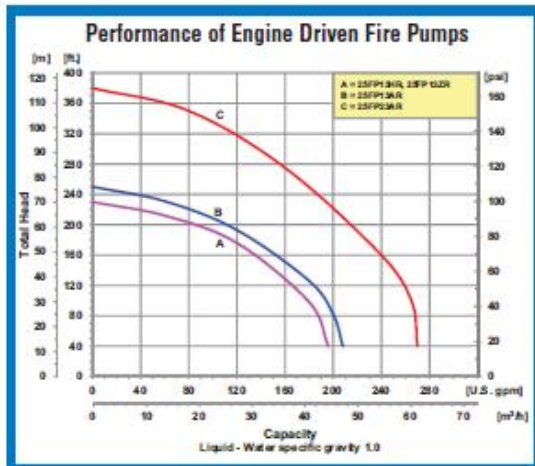



Engine Driven High Pressure/Fire Pumps

Pump Dimensional & Specification Data

Model	Curve	Driver	Seal Type & Elastomer/Faces	Prime Feature	Tank Size (Gal/Ltr)	Run Time (Hr.)	Ship Wt. (Lbs.)
25FP13ZR	A	Hatz 1B50 ^{▲▲}	Viton [®] Silicon Carbide/Carbon	Hand	1.32/5.0	1.8	295
25FP13HR	A	Honda GX390 ^{▲▲}	Viton [®] Silicon Carbide/Carbon	Hand	1.6 / 6.1	2.5	200
25FP13AR	B	B & S Vanguard 13 HP ^{▲▲}	Viton [®] Silicon Carbide/Carbon	Exhaust	2.25/8.5	1.8	225
25FP23AR	C	B & S Vanguard 23 HP ^{▲▲}	Viton [®] Silicon Carbide/Carbon	Exhaust	10/37.8	7.0	255

Construction: Aluminum

▲ Oil Alert Included

▲▲ Electric Start

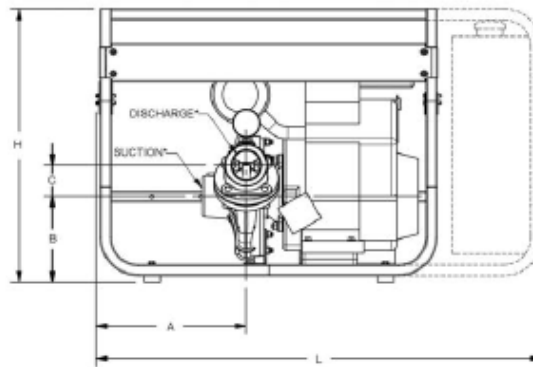
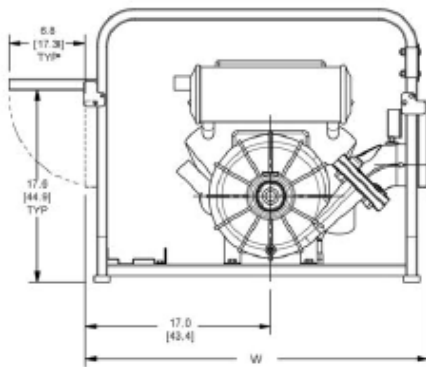

Hand Primer Not Shown for Model 25FP13HR

Model	HP Class*	SUC*	DIS*	A	B	C	L	W	H
25FP13ZR	13 HP	2-1/2	2-1/2	13.3 [33.7]	8.1 [20.6]	4.6 [11.7]	31.8 [80.8]	31.6 [80.3]	25.1 [63.8]
25FP13HR	13 HP	2-1/2	2-1/2	13.3 [33.7]	6.8 [17.4]	4.6 [11.7]	31.8 [80.8]	31.6 [80.3]	25.1 [63.8]
25FP13AR	13 HP	2-1/2	2-1/2	13.3 [33.7]	6.8 [17.4]	4.6 [11.7]	31.8 [80.8]	31.6 [80.3]	25.1 [63.8]
25FP23AR ^(†)	23 HP	2-1/2	2-1/2	13.8 [35.2]	7.9 [20.1]	2.8 [7.2]	41.0 [104.3]	31.6 [80.3]	25.1 [63.8]

(*) HP Class represents market category and is not intended to define actual horsepower.

(*) Standard NPT (Male) pipe thread.

NOTE: Dimensions are in Inches (centimeters) and have a tolerance of $\pm 1/8"$.

(†) Minimal Assembly Required: Auxiliary Fuel Tank Shipped Uninstalled

Standard Features

- Aluminum Construction with Replaceable Hard Coat Anodized Wear Ring
- Viton[®] Mechanical Seal with Silicon Carbide & Carbon Faces
- 2-1/2" NPT Suction & Discharge Ports
- Exhaust Prime or Hand Prime Depending on Model
- Built-in Discharge Check Valve
- Discharge Pressure Gauge Included
- Choice of Briggs & Stratton Vanguard, Honda Gasoline or Hatz Diesel Engines with 12 Volt DC Electric Start
- Maximum Temperature 200° F
- Optional NPT to Fire Hose Thread Available - See Accessories Page
- Heavy Duty Steel Roll Frame with Battery Tray Included
- Optional High Pressure Hose Kit or Wheel Kit Available



Manufacturer of AMT & IPT Pumps

400 Spring Street • Royersford, PA 19488 USA

www.amtpump.com • 888-amt-pump (268-7867)

The Gorman-Rupp Company reserves the right to discontinue any model or change specifications at any time without incurring any obligation.
©2012 American Machine and Tool Company. All rights reserved.



0414