

## 6.5HP Briggs Vanguard AMT Pump Package Specifications

### Key Features:

- Briggs Vanguard engine, 6.5 HP, low oil shutoff
- AMT (American Machine & Tool) Single stage impeller, aluminum alloy with 2.0" intake
- Pump produces Max 108 PSI; 70 PSI at 70 GPM
- Pump sprays water 80 Feet from 1.5" nozzle after 100 feet of fire hose
- 15 Foot 2.0" Suction hose with Cam Lock fitting and filter
- Pressure Relief Valve protects pump when nozzles closed and engine running
- Two fire hose connections: 1.5" and 1.0" that can run concurrently
- 200 feet of Fire Hose (150' of 1.5", 50' of 1.0") with nozzles for each size hose (barrel style, twist on/off)

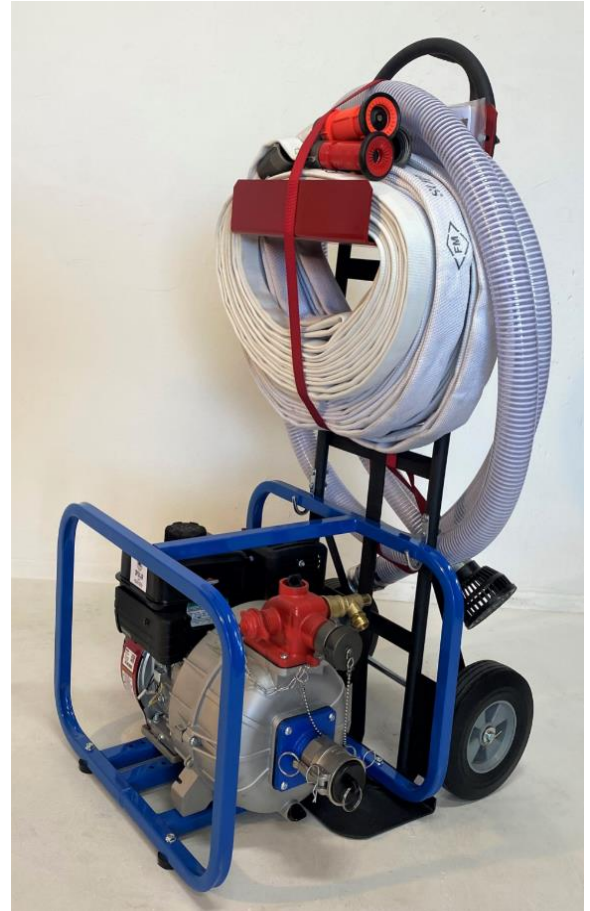

**Fire Pump frame is carried on 2-wheel equipment cart and can be removed from cart for transport by SUV or truck.**

**Cart has no-flat wheels and Operating and Maintenance Instructions attached**



**Fire Pump and Hose Packages LLC**

1654 West 11<sup>th</sup> Street Upland, CA 91786  
 Office (800) 797-1310 Fax (866) 888-883-6160

*Helping Homeowners protect property from Wildfires with Water Tanks, Fire Retardant Sprayers and Gel, and portable high pressure water pump packages.*

**6.5HP Briggs Vanguard AMT Pump Package Specifications**



**Pump Performance Curves  
6 to 13 HP Engines**

Fire Pump Package	6.5Hp Briggs AMT
<b>Pump Pressure (PSI) at:</b>	
70 GPM	70
100 GPM	45
150 GPM	-
200 GPM	-
250 GPM	-
<b>Water Spray from 1.5" Nozzle after 100 Feet of Fire Hose</b>	<b>80+</b>
<b>Factors Affecting Selection:</b>	
Portable	YES
Thermo Gel as primary protection	YES
Water Supply < 3k Gal	YES
Nozzle 20'+ higher than Pump (A)	NO
Nozzle 40'+ higher than Pump (A)	NO
Hose/Pipe Run > 400' level ground	NO
Two 1.5" Fire Hoses Concurrently	NO
Electric Start	NO
Perimeter High Volume Sprinkler System	NO
Exhaust driven Primer	NO
Salt Water	NO
Diesel Fuel	NO
<b>Fire Hose in Standard Package</b>	<b>200 Feet</b>
<b>Pricing US\$, excluding shipping and CA Sales Tax</b>	
Manual Start	\$ 2,499
Electric Start (C)	Not Avail

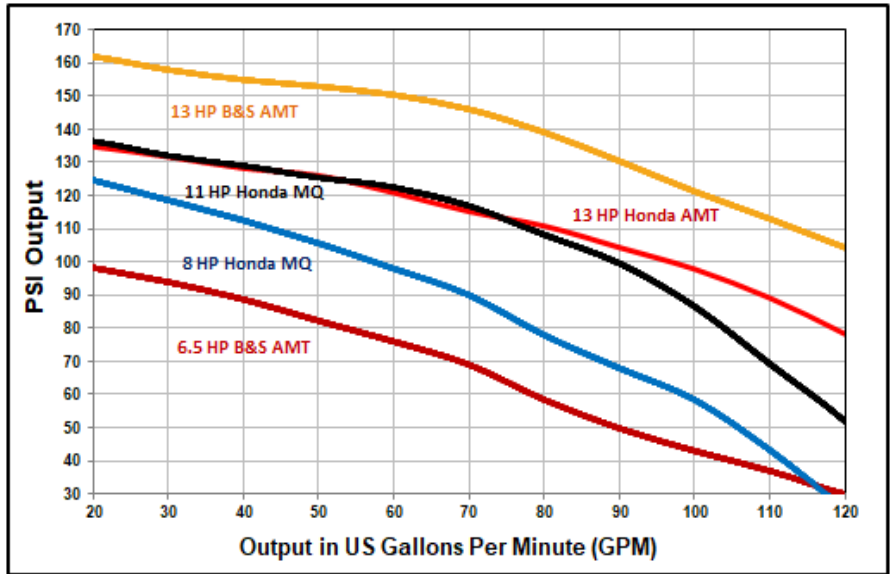

Sold by: Fire Pump and Hose Packages LLC [www.FirePumpAndHose.Com](http://www.FirePumpAndHose.Com)  
 Email: [Info@FirePumpAndHose.Com](mailto:Info@FirePumpAndHose.Com) (800) 797-1310

**Options Available:**

- Thermo Gel Sprayer and Concentrate
- Phos-Chek Foam Concentrate and Foam Sprayer
- Upgraded Pistol Grip D-Handle Nozzle
- Custom Pump Cover for protection of equipment from weather
- Water Tank connection fittings
- Lake/Ocean Float Dock for Suction Hose
- High Volume Filter for Suction Hose





**Model 2P5XHR**

**2" Engine Driven Portable High Pressure Pumps**

- **Cast Aluminum Construction**
- **EPDM/EPR Mechanical Seals**
- **Optional Viton® Seal and Elastomers Available**
- **2" Cast Iron Suction & Discharge Male NPT Port Sizes**
- **Maximum Flow up to 130 GPM**
- **Maximum Head up to 108 PSI**
- **Maximum Lift to 26 Ft.**
- **One Tool Serviceability**
- **Utilized for Fire Protection or Irrigation**
- **Discharge Port Rotates in 90° Increments**
- **Engine Options: Honda, Briggs & Stratton Gasoline or Hatz Diesel Engines**
- **Optional High Pressure Hose Kit and Wheel Kit Available**

**High Pressure Hose Kit 55-338**

IPT 2" Engine Driven Portable High Pressure pumps are cast aluminum construction with cast iron volute and male NPT ports. Pump applications include fire protection and irrigation. These pumps are available with a wide choice of standard and heavy duty gasoline or diesel fueled engines. These pumps feature high efficiency closed cast aluminum impeller. All models come equipped with EPDM/EPR elastomers and seals. Most models include a heavy duty steel roll frame.

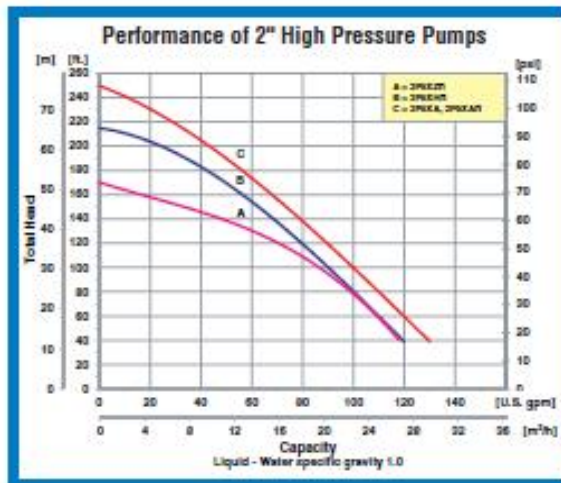

**IPT ENGINE DRIVEN HIGH PRESSURE PUMPS**



## Engine Driven Portable High Pressure Pumps

### Pump Dimensional & Specification Data

Model	Curve	Driver	Seal Type & Elastomer/Faces	Tank Size (Gal/Ltr)	Run Time (Hr.)	Mounting	Ship Wt. (Lbs.)
2PSXA	C	Briggs & Stratton Vanguard <sup>▲</sup>	EPDM/EPR/CAR/CER	0.87 / 3.3	1.3	Handle	70
2PSXAR	C	Briggs & Stratton Vanguard <sup>▲</sup>	EPDM/EPR/CAR/CER	0.87 / 3.3	1.3	Roll Cage	90
2PSXHR	B	Honda GX160 <sup>▲</sup>	EPDM/EPR/CAR/CER	0.82 / 3.1	2.8	Roll Cage	90
2PSXZR	A	Hatz Diesel 1820	EPDM/EPR/CAR/CER	0.79 / 3.0	2.7	Roll Cage	110

Construction: Cast Aluminum with Cast Iron Components

▲ Of Alert Included

#### 5/8 Threaded Kit (Single)

Model	Seal Type & Elastomer/Faces	Mounting	Ship Wt. (Lbs.)
2PSX	EPDM/EPR/CAR/CER	Handle	35

#### 2" High Pressure Hose Kit

Model	Ship Wt. (Lbs.)
55-338	40

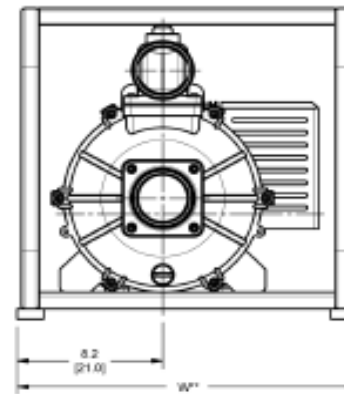
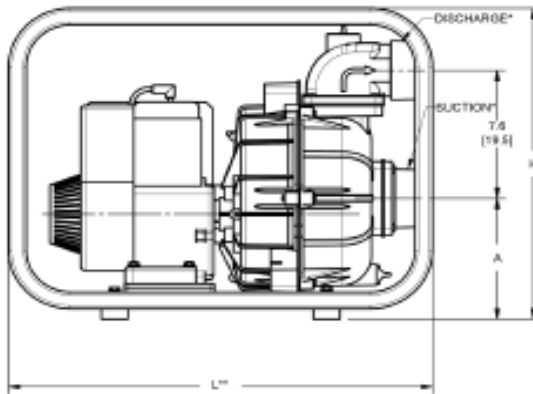

Model	HP Class*	SUC*	DIS*	L**	W**	H
2PSX	5 HP	2	2	24.0 [60.9]	19.2 [48.9]	18.6 [47.3]

Gasoline Models	HP Class*	A
2PSX	5 HP	7.4 [18.7]

Diesel Models	HP Class*	A
2PSXZR	5 HP	7.9 [20.0]

(\*) HP Class represents market category and is not intended to define actual horsepower.

(\*) Standard NPT (Male) pipe thread.

(\*\*) This dimension may vary due to engine manufacturer's specifications.

NOTE: Dimensions are in inches (centimeters) and have a tolerance of ± .1/8".

### Standard Features

- Aluminum Closed Impeller and Cast Iron Volute-Die Cast Aluminum Pump
- Large Pump Casing Increases Capacity
- Built-in Check Valve for Fast Priming
- Removable/Replaceable Cast Iron Suction & Discharge Flanges
- Discharge Port Rotates in 90° Increments
- EPDM/EPR Seal with Carbon and Ceramic Faces with Optional Viton® Seals and Elastomers
- One Tool Serviceability, Tool Included with Engine Driven Models (Not with Kits)
- Choice of Briggs & Stratton, Honda Gasoline or Hatz Diesel Engines
- Includes Strainer and Rubber Foot Mounting
- Maximum Temperature 180° F
- Pedestal Versions Available
- Optional High Pressure Hose Kit and Wheel Kit Available
- QSP - Quick Ship Pumps



Manufacturer of AMT & IPT Pumps

400 Spring Street • Royersford, PA 19468 USA

[www.amtpump.com](http://www.amtpump.com) • 888-amt-pump (268-7867)

The Gorham Rupp Company reserves the right to discontinue any model or change specifications at any time without incurring any obligation. ©2017 American Machine and Tool Company. All rights reserved.



0513

FIRE-4